

Preparing for the IS1 exam

EXAM Nov 1 2015

Question 1

For each of the following statements, determine whether it is true or false. Justify your answers carefully.

- 1 Some internal influencers can be strengths for achieving goals.
2. Some external influencers can be weaknesses for employing means.
3. Business models are primarily useful for representing and reasoning about procedural aspects of business communication, including document exchange.
4. An exchange process that includes use stockflows must also include take stockflows.
5. Only economic contracts can fulfil economic commitments.

Question 1

For each of the following statements, determine whether it is true or false. Justify your answers carefully.

6. An economic commitment is always related to at least two economic agents.
7. In an EPC diagram, an event can sometimes be immediately followed by another event.
8. “The revenue shall increase by more than 25% until the end of 2018” is a good formulation of an objective.
9. ERP systems are more useful for goods producing companies than for service producing companies in the public sector.

Question 10 is not part of the course content any longer

10. The following is an example of a directive speech act: “I will give you a teddy bear for Christmas”.

Question 3 - VDML

- You have been hired to design a new business model for Airbnb, see question 2.
- Construct a VDML model for the value network around Airbnb. Make sure to describe the value propositions clearly. (You may make your own assumptions for solving this.)

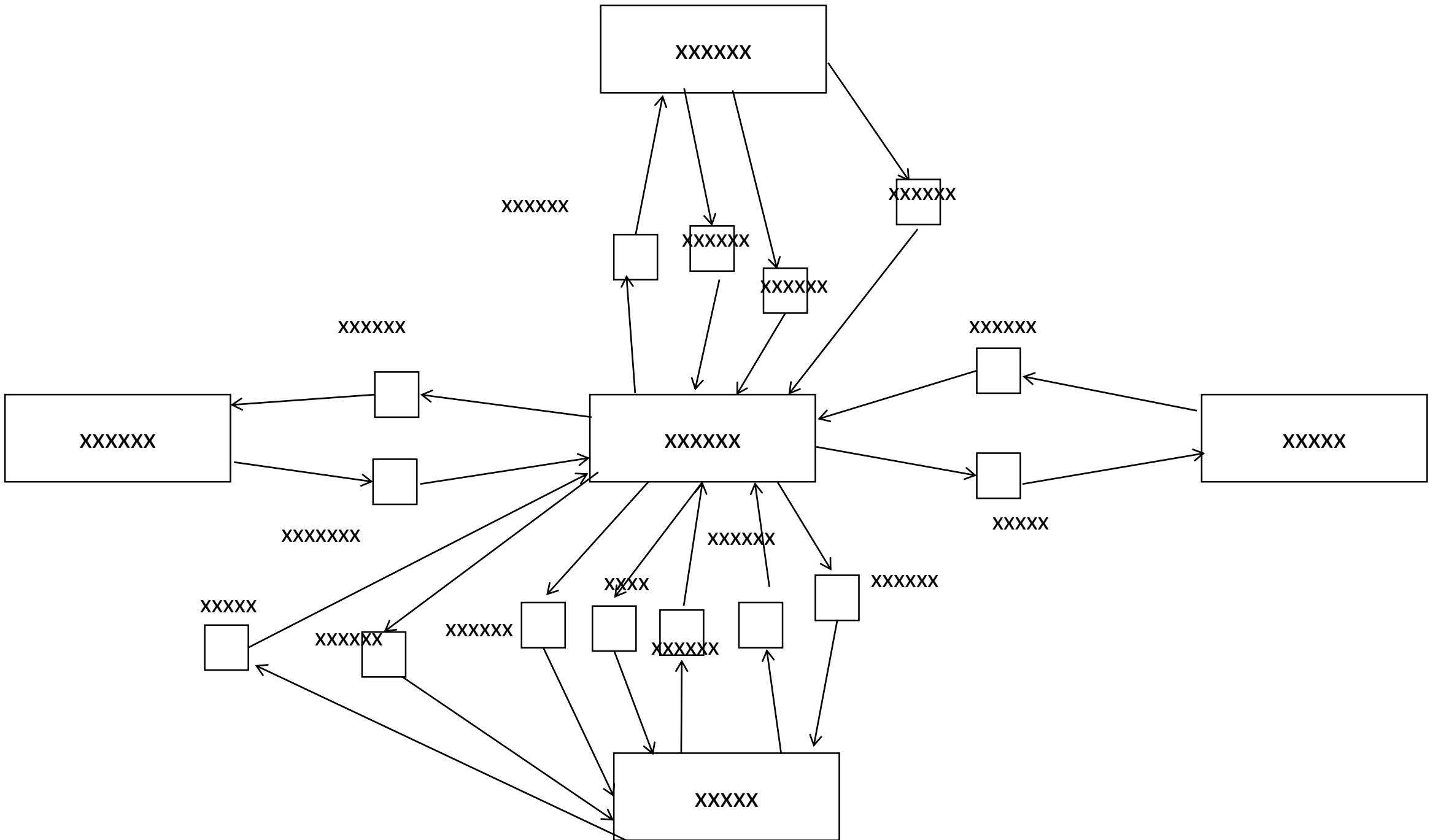

Question 4 (a, b and c) - REA model

There are two different ways in which a guest can rent a room at Airbnb:

1. The customer wants a room of a certain size in a certain city, but he or she does not care about exactly which room. For example, she says “I want a room for two persons in Amsterdam”. A contract will then be established with Airbnb and later on Airbnb will provide a room fulfilling the requirements given by the guest.
2. The customer wants a specific room at a specific place. For example, she says “I want the room at the third floor of Hoijenstrasse 15 in Amsterdam”. Airbnb will then provide her this room.

Question 4 (a, b and c) - REA model

- a) Construct an exchange diagram (including commitments and contracts) for case 1. above. Relate your diagram to REA using stereotypes.
- b) Construct an exchange diagram (including commitments and contracts) for case 2. above. Relate your diagram to REA using stereotypes.
- c) Identify a conversion process that can occur at Airbnb. Construct a diagram for this process. Relate your diagram to REA using stereotypes.

XXXXXXXX

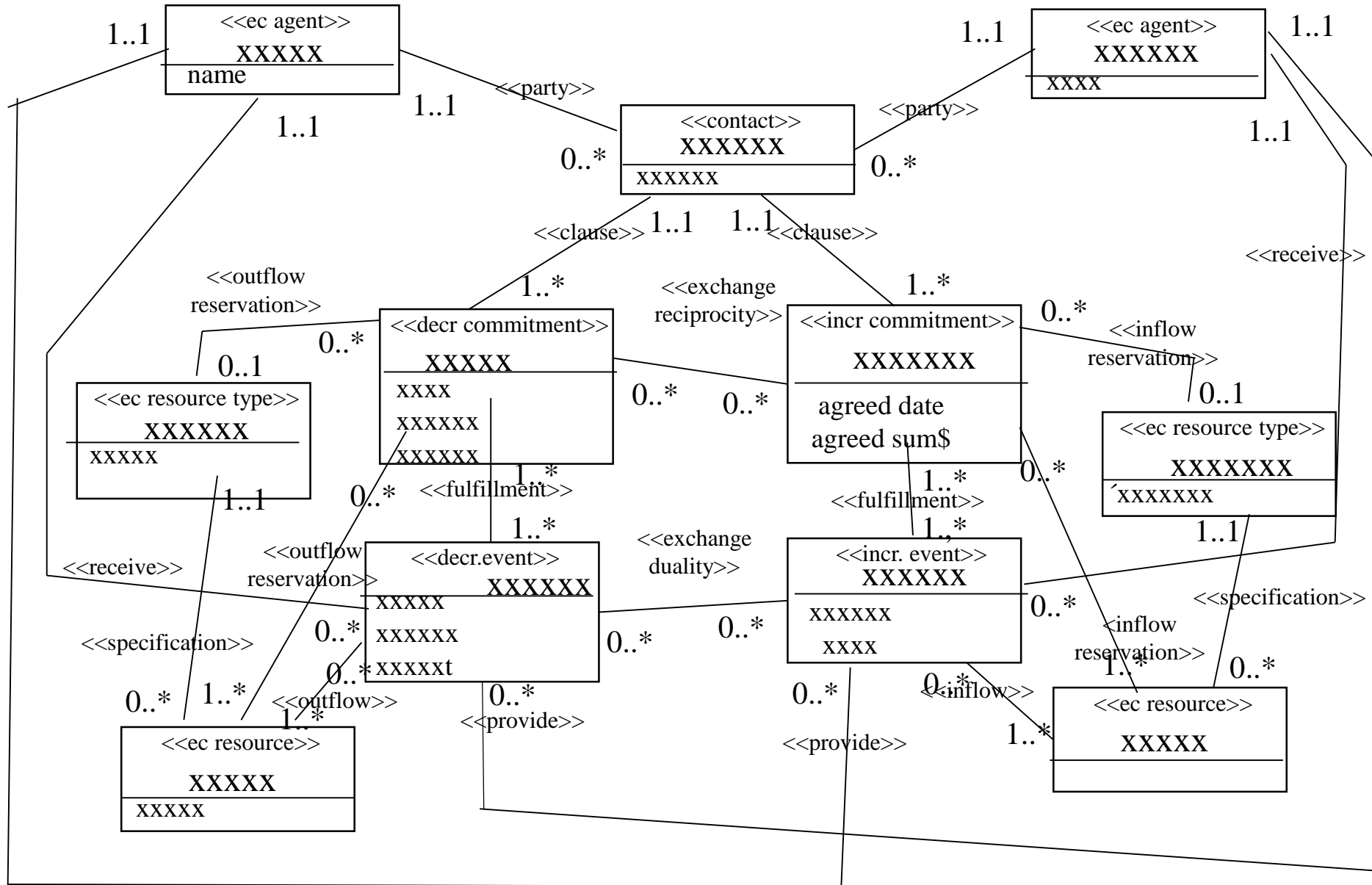

XXXXXXXX

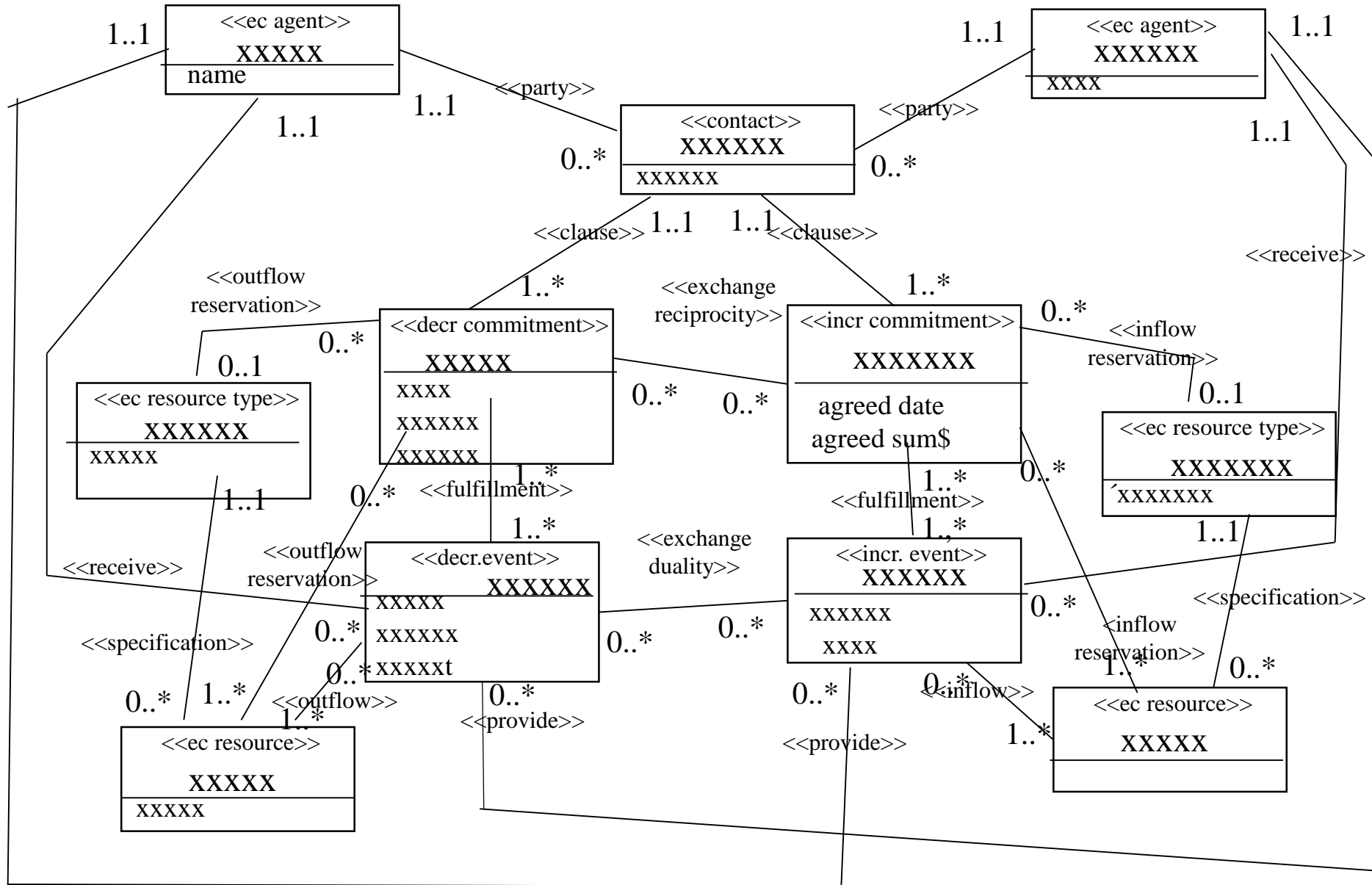

XXXXXX

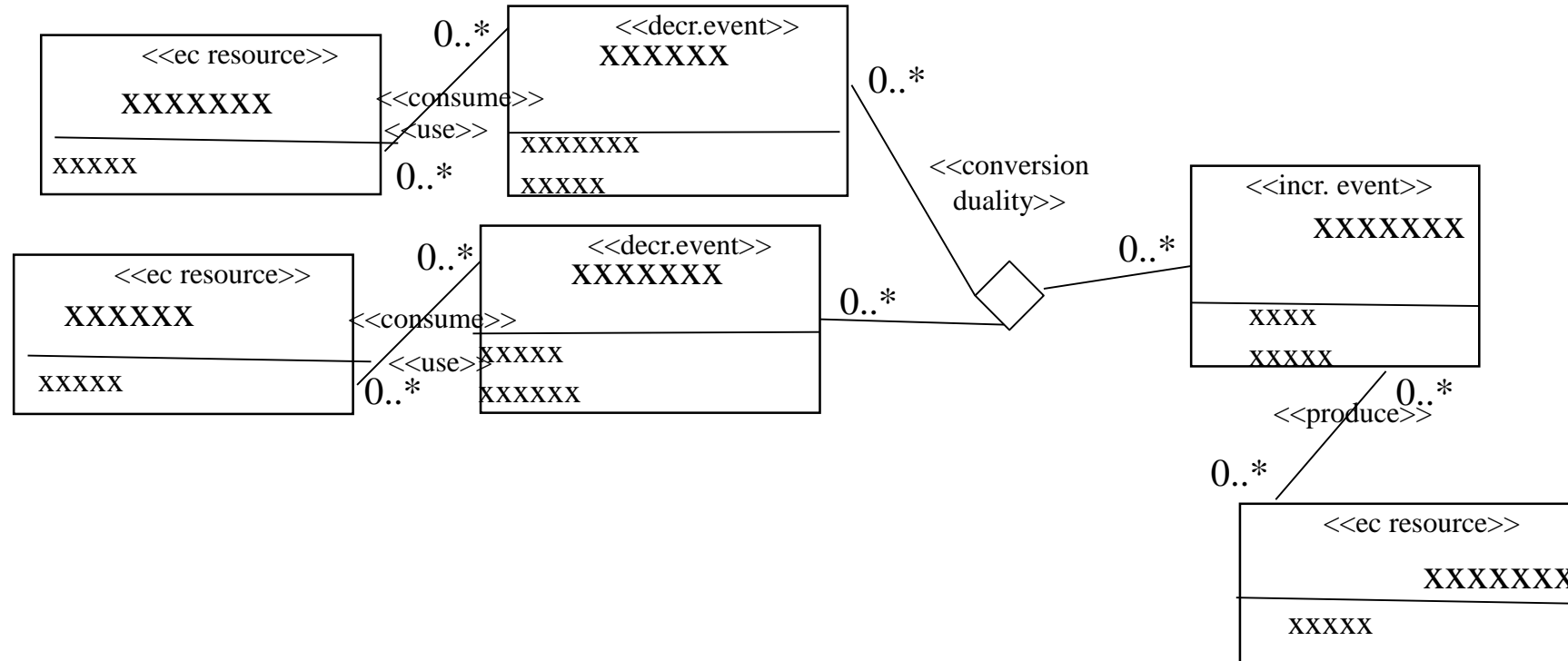

Question 2 - Goal model

- Construct a goal model for Airbnb. The model should include at least:
- 6 goals
- 6 means
- One means for every leaf goal
- One objective for every leaf goal
- 6 influencers
- One influencer that is both a strength and a weakness (mark this one clearly in your diagram)

Question 2 - Goal model

Is the following a goal, objectives, means, internal or external influencer?

- Some hotels are planning to offer services similar to the one of Airbnb
- Travelling is increasing worldwide
- Many people think ordinary hotels are boring
- Some hosts at Airbnb have been unreliable
- Increased market share
- To be available in more than 50000 cities at the end of 2017
- To offer not only rooms but also food and drink
- Many people are very concerned about safety
- To expand rapidly worldwide
- Many people like to see how others live in their daily lives

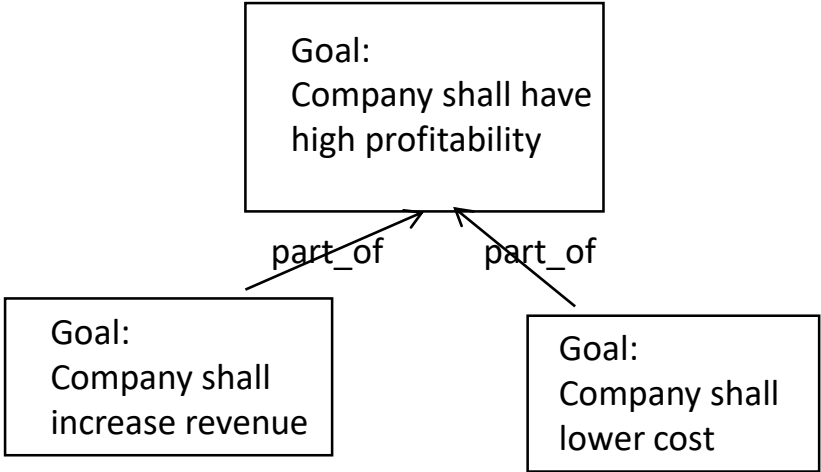

Question 4 (d) - EPC

- Airbnb uses the following process for accepting new hosts. First, a potential host sends in an application, which contains information about address, room size, bathroom availability, etc. The potential host also suggests a price. Airbnb checks that the information seems reasonable. Airbnb also checks that there are no criminal records. Furthermore, Airbnb checks the price. If it seems too low or high, Airbnb asks the potential host to adjust the price. And the potential host may or may not agree to the adjustment. Finally, Airbnb decides whether to accept the potential host or not.
- Construct an EPC diagram for the process above. The text is incomplete, so you need to make your own assumptions.

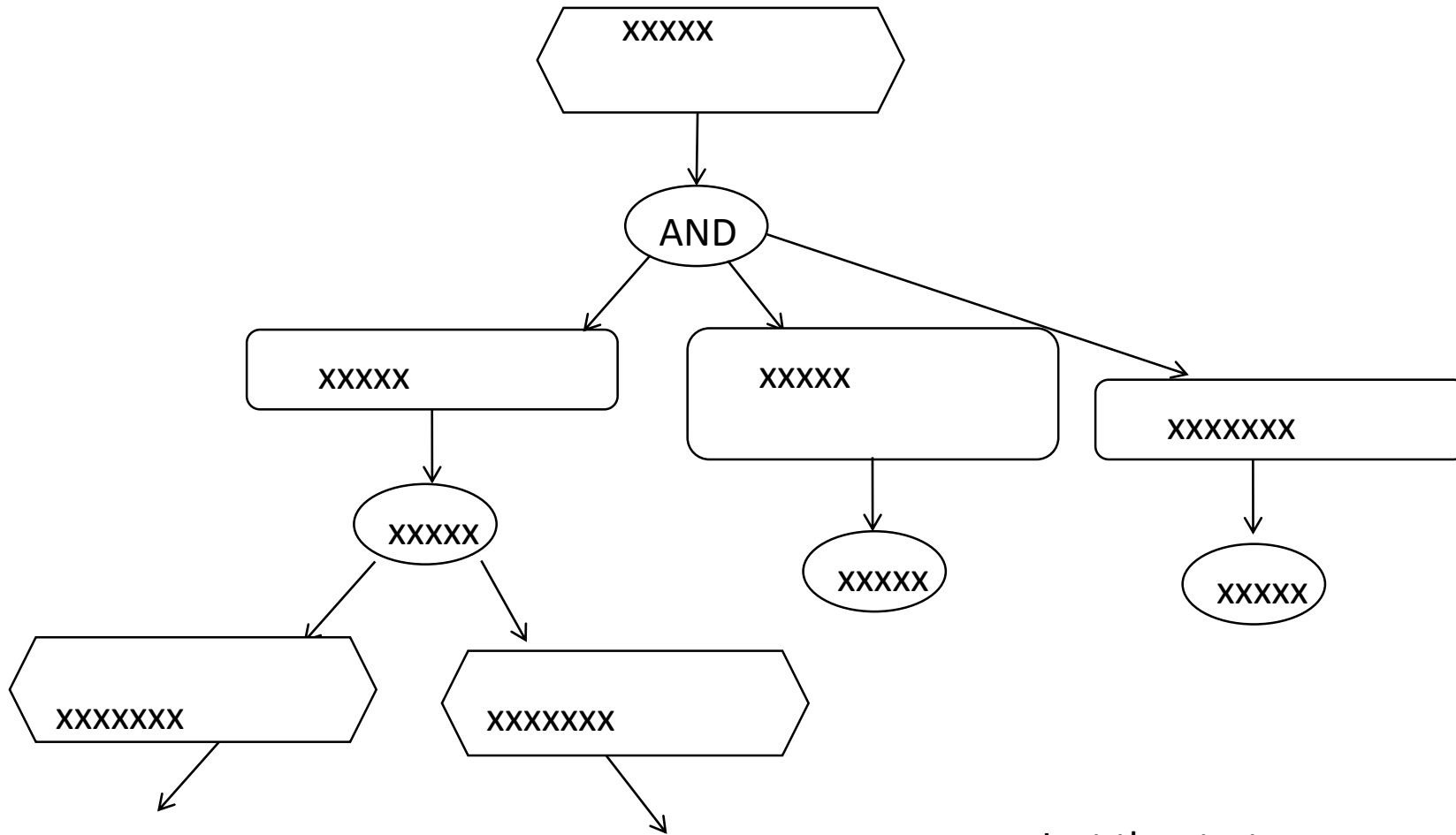

Just the start
of the EPC

EXAM Oct 28 2014

Question 1

For each of the following statements, determine whether it is true or false. Justify your answers carefully.

1. The functions in a business process are less likely to change over time than the control flow (the word “functions” is here used in the EPC sense).
2. An EPC diagram shows logical order rather than temporal order.
3. In an EPC diagram, an or join must always be followed by an or split.
4. In BMM, an influencer can be both a threat and an opportunity for the same goal.
5. The following is a good formulation of an objective: “The competence level of the personnel shall increase during 2015” (the word “objective” is here used in the BMM sense).
6. Some influencers are both internal and external.

Question 1

For each of the following statements, determine whether it is true or false. Justify your answers carefully.

7. Both take and give stockflows can occur in an exchange process.
8. Only use and produce stockflows can occur in a conversion process.
9. ERP systems are primarily useful for managing customer relationships.

Statement 10-12 are not part of the course content any more

10. “Ronald Reagan was the 40th President of the United States” is an example of an assertive speech act.
11. Every e3value model must include at least one market segment.
12. E3value models are useful for representing communication and control flow.

Question 2 – Goal model

Is the following a goal, objectives, means, internal or external influencer?

- Amazon is about to offer a streaming service similar to the one of Oyster
- More and more people own a tablet
- High profit
- People want to own their books
- People want to write notes in their books
- To have more than 10,000 paying customers at the end of 2015
- Introduce a complementary service that transforms text in a book to speech

Question 3 – VDML (instead of e3)

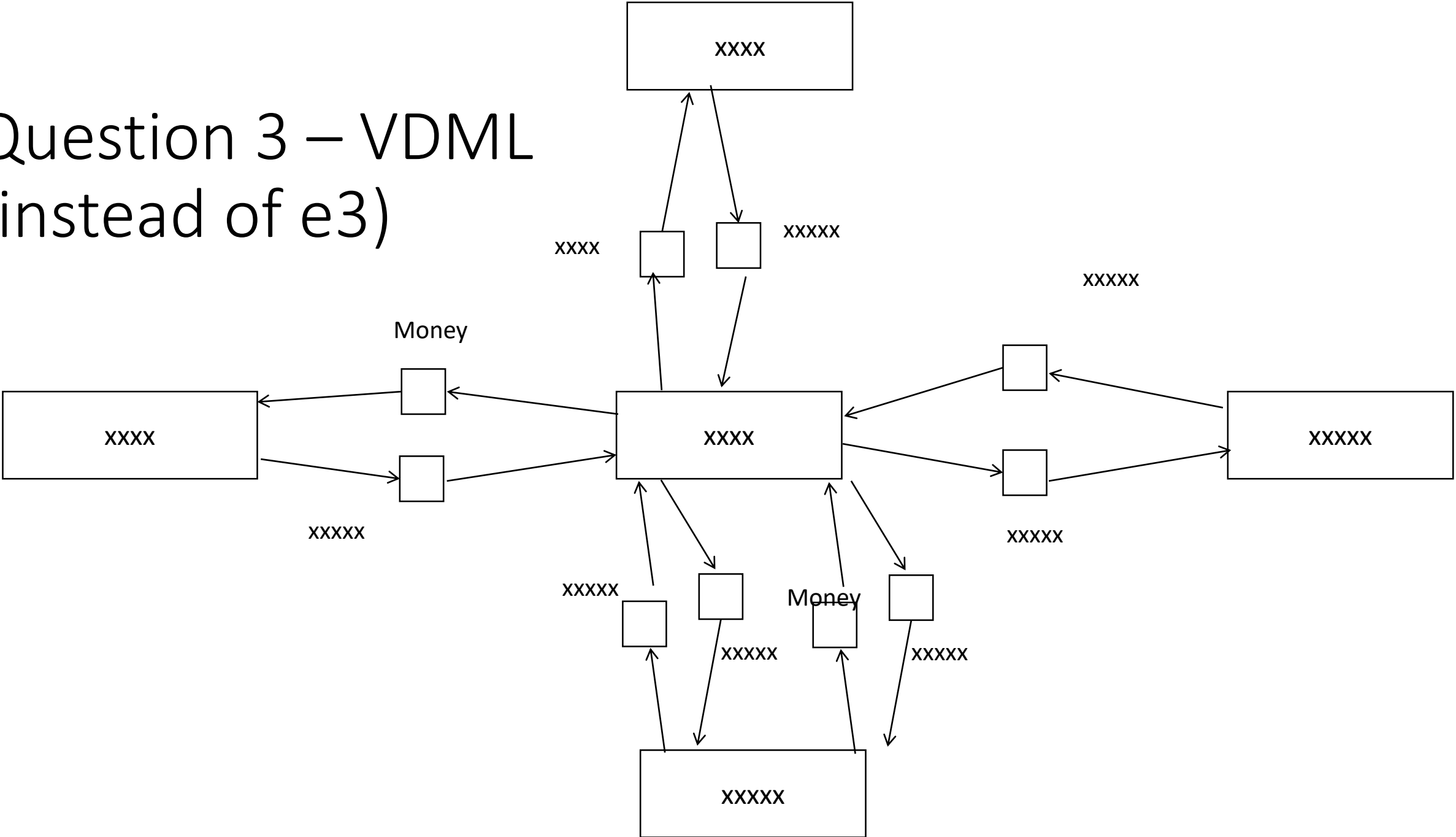

Question 4 - REA based conceptual model

- A company produces and sells jewelry, such as necklaces, earrings and bracelets. As it produces the jewelry itself, it needs to procure material, such as gemstones, coins and other precious material. It also needs to procure more inexpensive items, including glass, beads and wire. Identify at least two exchange processes and at least one conversion process for the company. Describe these processes by means of one (or several) class diagram(s) using the REA pattern. Make explicit which classes in your model that correspond to which classes in the REA pattern

Question 4 - REA based conceptual model

Your model must be able to handle the following information requirements:

- How many diamonds has the company purchased?
- How many customers have ordered earrings that cost more than 100 euros?
- How many necklaces have been produced during 2013?
- How many earrings with beads have been produced during 2013?
- Which is the most ordered necklace?
- How many suppliers have sold beads to the company?
- Which necklaces include beads that cost more than 10 euros each?
- Which purchase orders have not yet been fulfilled (i.e. the deliveries have not been made to the company)?

XXXXXXXX

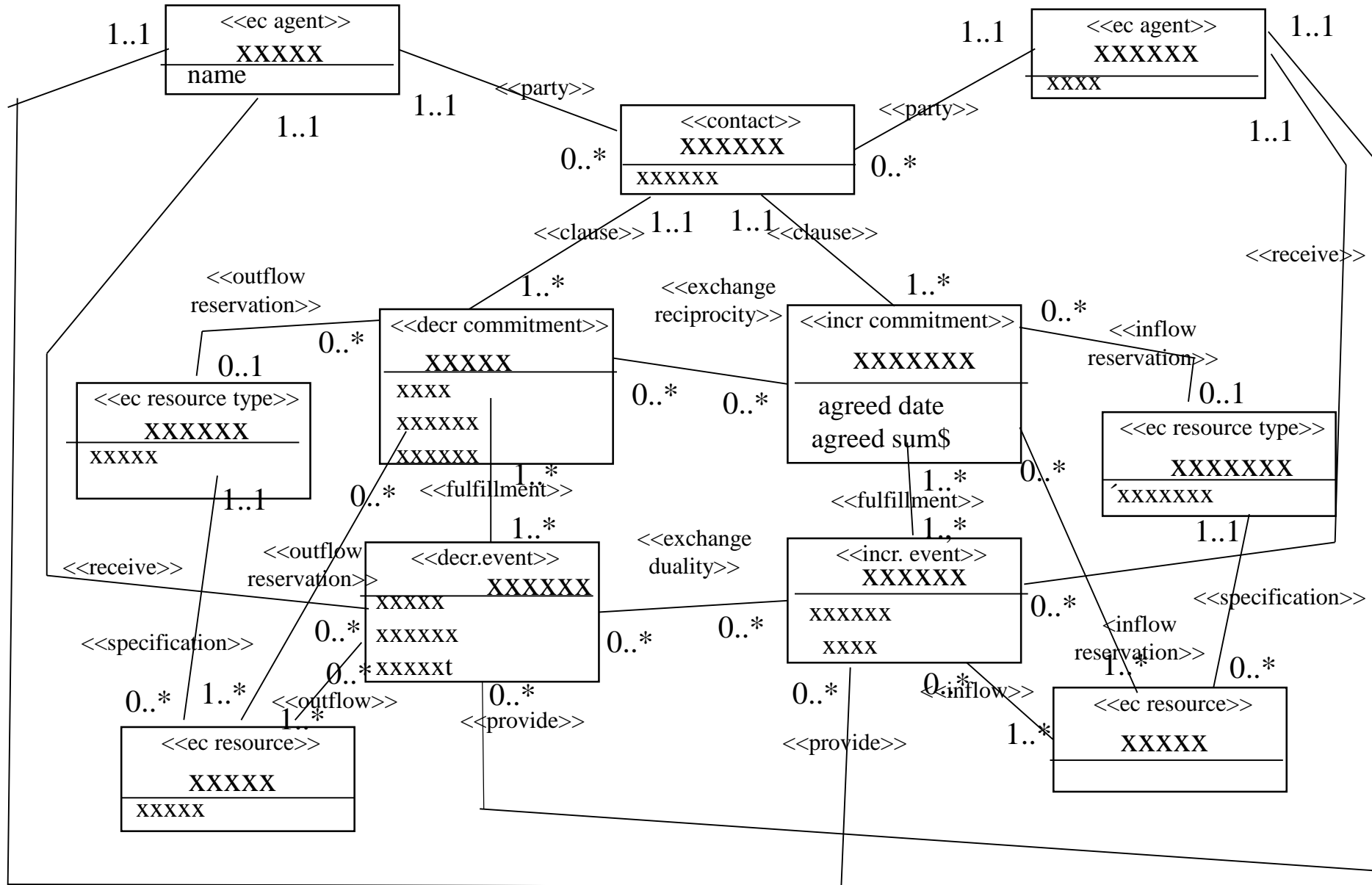

XXXXXXXX

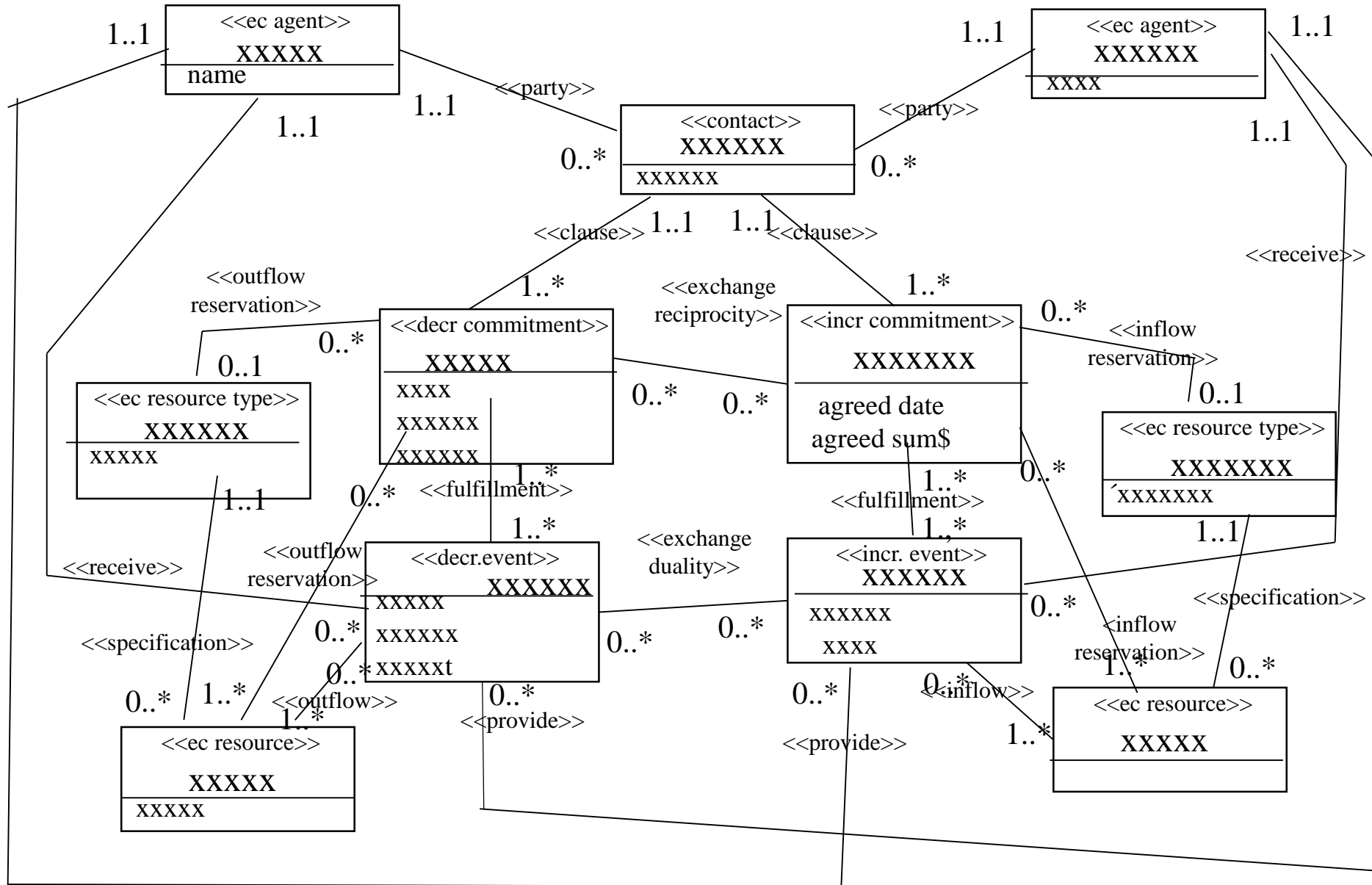

XXXXXX

